



03 28 64 98 09
 contactweb@dbmoteurs.fr
 www.dbmoteurs.fr

EN SAVOIR PLUS



VOLVO PENTA INBOARD DIESEL

D13-MH

12.78 liter, in-line 6 cylinder with Exhaust aftertreatment system

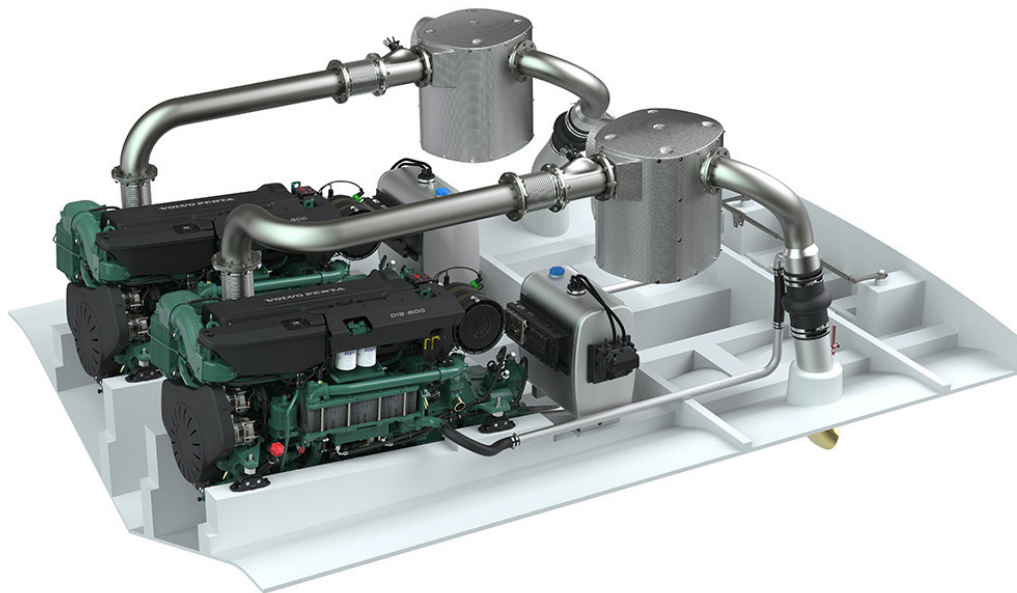

Technical Data

Engine designation	D13 MH			
Configuration	in-line 6			
Method of operation	4-stroke, direct-injected, turbocharged diesel engine with charge air cooler			
Bore/stroke, mm (in.)	131/158 (5.16/6.22)			
Displacement, l (in ³)	12.78 (779.7)			
Compression ratio	18.5			
Dry weight bobtail (KC), kg (lb)	1480 (3263)			
Dry weight bobtail (HE), kg (lb)	1520 (3351)			
	Rating 1	Rating 1	Rating 1	Rating 2
	1800 rpm	1800 rpm	1800 rpm	1900 rpm
Crankshaft power, kW (hp)	294 (400)	331 (450)	368 (500)	441 (600)
Max. torque, Nm (lbf.ft) @ 1400 rpm	1821 (1343)	2064 (1522)	2292 (1690)	2601 (1918)
Emission compliance	IMO Tier III, US EPA Tier 3, Stage V	IMO Tier III, US EPA Tier 3	IMO Tier III, US EPA Tier 3	IMO Tier III, US EPA Tier 3
Recommended fuel to conform to	ASTM-D975 1-D & 2-D, EN 590, JIS KK 2204 or HVO. Max 1000PPM.			
Flywheel housing/SAE size	14"/SAE1			

Technical data according to ISO 3046 Fuel Stop Power and ISO 8665. Fuel with a lower calorific value of 42700 kJ/kg and density of 840 g/liter at 15 °C (60 °F). Merchant fuel may differ from this specification which will influence engine power output and fuel consumption. Ratings R1 & R2, see explanation in Volvo Penta's Product Guide.

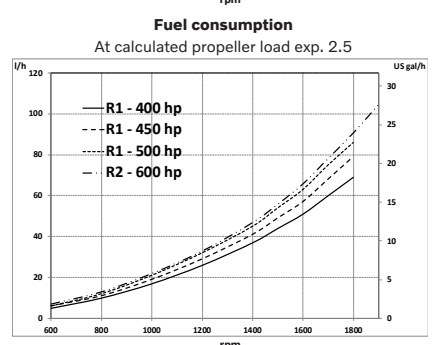
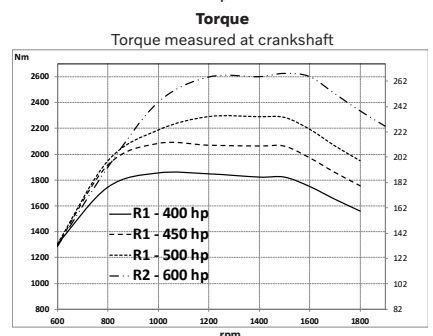
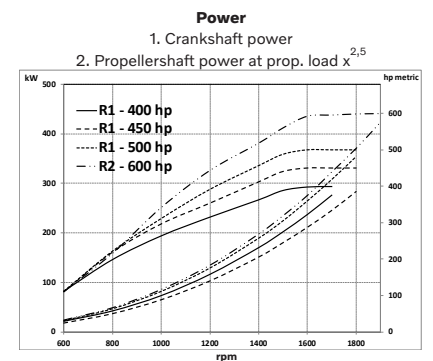

D13-MH

12.78 liter, in-line 6 cylinder with Exhaust aftertreatment system

EN SAVOIR PLUS

Technical description

Engine and block

- Cylinder block and cylinder head made of cast-iron
- One-piece cast-iron cylinder head
- Ladder frame fitted to engine block
- Replaceable wet cylinder liners and valve seats/guides
- Drop forged crankshaft with induction hardened bearing surfaces and fillets with seven main bearings
- Four valve per cylinder layout with overhead camshaft
- Each cylinder features cross-flow inlet and exhaust ducts
- Gallery oil-cooled cast aluminum alloy pistons with three piston rings
- Rear-end transmission

Engine mounting

- Flexible engine mounting (option)

Lubrication system

- Integrated oil cooler in cylinder block
- Twin full flow oil filters and by-pass filters of spin-on type

Fuel system

- Electronic Unit Injectors, one per cylinder, vertically positioned at the center in between the four valves
- 5-hole high pressure injector nozzles
- Gear-driven fuel pump, driven by timing gear
- Electronically controlled central processing system (EMS – Engine Management System)
- Electronically controlled injection timing
- Twin spin-on fine fuel filters with change over valve

Air inlet and exhaust system

- Air filter with replaceable inserts
- Mid-positioned twin entry turbocharger and charge air cooler

Cooling system

- Freshwater-cooled charge air cooler
- Seawater-cooled plate heat exchanger
- Coolant system prepared for hot water outlet
- Easily accessible seawater impeller pump in rear end

Electrical system

- 24V/110A alternator

Instruments/controls

- Three options for onboard electronic control:
 1. EVC (Electronic Vessel Control), a type-approved system with integrated controls and features.
 2. MCC (Marine Commercial Control), an open system that is type-approved. Incl. separate safety shutdown system
 3. Open CAN Interface, engine delivered without control system. Different options with or without shut down senders and switches.

Exhaust aftertreatment system

- SCR (Selective Catalytic Reduction)
- Aqueous UREA solution 32% or 40%
- Complete system – developed, certified, and serviced by one company
- Fully integrated capabilities
- Prop-to-helm system (IPS)
- SCR unit reduces noise by up to 35 dBA
- Wide range of installation options available

Dimensions

Not for installation, mm [in.]

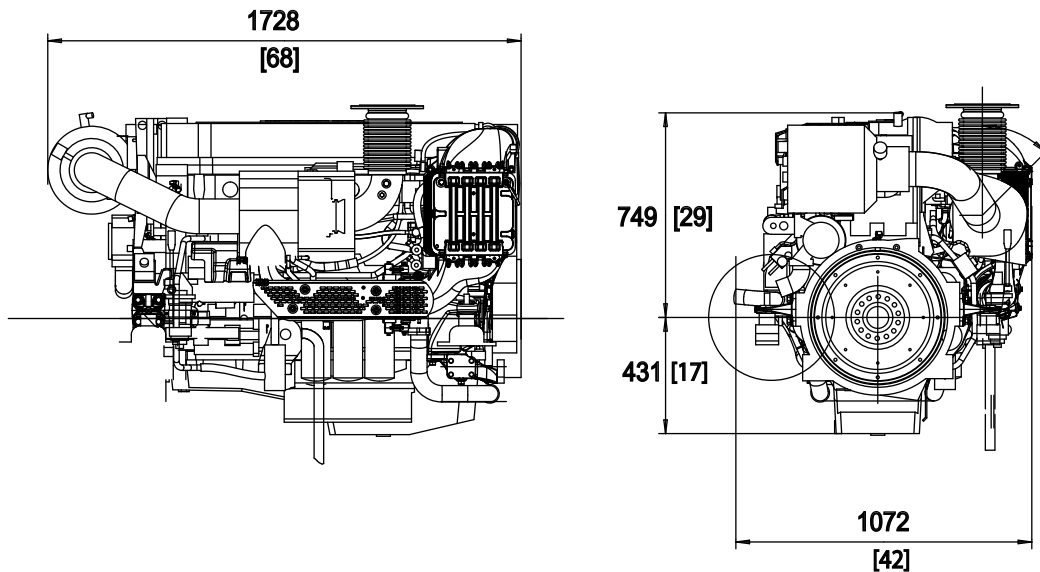

Not all models, standard equipment and accessories are available in all countries. All specifications are subject to change without notice. The engine illustrated may not be entirely identical to production standard engines.



03 28 64 98 09
contactweb@dbmoteurs.fr
www.dbmoteurs.fr

EN SAVOIR PLUS

**VOLVO
PENTA**

AB Volvo Penta

SE-405 08 Göteborg, Sweden
www.volvopenta.com

Contact your local Volvo Penta dealer for more information regarding Volvo Penta engines and optional equipment/accessories or visit www.volvopenta.com

IOS



Android



Download the Volvo Penta dealer locator App for your iPhone or Android