

# D7A TA

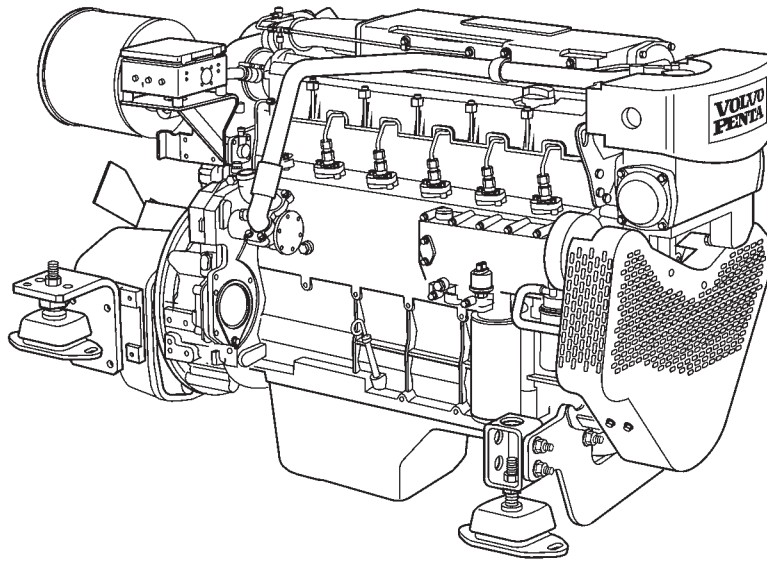

## Technical Data

Engine designation	D7A TA		
No. of cylinders and configuration	in-line 6		
Method of operation	4-stroke, direct-injected, turbocharged diesel engine with aftercooler		
Bore/stroke, mm (in.)	108 (4.25)/130 (5.12)		
Displacement, l (in <sup>3</sup> )	7.15 (436)		
Compression ratio	17.6:1		
Dry weight bobtail, kg (lb)	690 (1521)		
Dry weight with reverse gear ZF280, kg (lb)	760 (1676)		
	Rating 2 2300 rpm	Rating 1 2300 rpm	Rating 1 1900 rpm
Crankshaft power, kW (hp)	174 (237)	148 (201)	130 (177)
Max. torque, Nm (lbf.ft) @ 1500 rpm	809 (596)	688 (507)	688 (507)
Specific fuel consumption, g/kWh (lb/hph) @ 2300 rpm	226 (0.366)	229 (0.371)	
g/kWh (lb/hph) @ 1900 rpm			213 (0.345)
Recommended fuel to conform to	ASTM-D975 1-D & 2-D, EN 590 or JIS KK 2204		
Emission compliance	IMO NO <sub>x</sub> , EU IWW, CCNR2		
Flywheel housing/SAE size	10"/11,.5"/SAE2, 10"/11,.5"/SAE3, 14"/SAE1		

Technical data according to ISO 3046 Fuel Stop Power and ISO 8665. Fuel with a lower calorific value of 42700 kJ/kg and density of 840 g/liter at 15 °C (60 °F). Merchant fuel may differ from this specification which will influence engine power output and fuel consumption.

Ratings R1 & R2, see explanation in Volvo Penta's Product Guide.

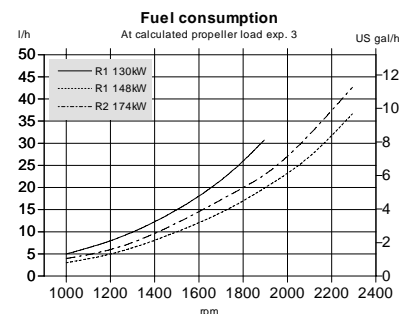
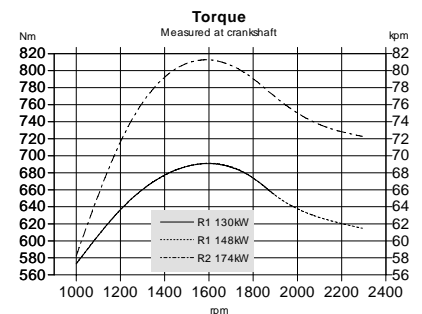
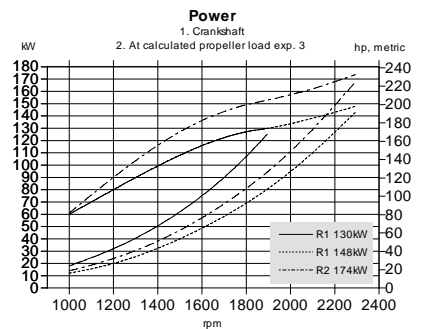

# D7A TA

## Technical description:

### Engine and block

- Cylinder block, head and flywheel housing made of cast iron
- Belt guard
- Combined 10" and 11.5" flywheel with SAE 2 housing
- Nitrocarburized transmission gears
- Press-hardened crankshaft
- Forged aluminum pistons
- Cylinder liners of wet type

### Lubrication system

- Oil filler in valve cover
- Oil sump made of cast iron
- Manual oil drain pump
- Rotary lubrication oil pump
- Freshwater-cooled oil cooler
- Full flow oil filters of spin-on type
- Closed crankcase ventilation system

### Fuel system

- Fuel feed pump
- Fine fuel filter of spin-on type
- Unit pumps
- Six-hole injectors
- Mechanical governor with smoke limiter
- Fuel stopping solenoid 24V

### Cooling system

- 2-circuit keel cooling system with expansion tank

- Gear-driven seawater pump
- Belt-driven freshwater pump
- Freshwater-cooled turbocharger and exhaust manifold

### Electrical system

- 2-pole 24V electrical system, 24V/55A alternator, 24V 4kW starter
- Senders and switches:
  - Tachometer
  - Lubrication oil pressure
  - Cooling-water temperature
  - Cooling-water level
- Rubber-suspended electrical terminal box with semi-automatic fuses and plug-in connection

### Optional equipment

#### Engine

- Flexible suspension for engine and reverse gear
- Combined 10"/11,5" flywheel with SAE 3 housing

#### Lubrication system

- Shallow oil sump
- Twin oil filters, for remote mounting

#### Fuel system

- Hand pump
- Jacketed fuel pipes
- Single or twin fuel/water separating pre filter

- Twin fuel filters, for remote mounting

### Exhaust system

- Exhaust elbow, wet
- Exhaust elbow, dry, with integrated flexible compensator
- Silencer, dry

### Cooling system

- Engine-mounted tubular heat exchanger with integrated expansion tank
- Seawater filter

### Electrical system

- 1-pole 12V electrical system, 12V/95A alternator, 12V/3.1kW starter
- 24V/140A alternator
- Engine heater 230V/820W
- Senders:
  - Charge air pressure
  - Gearbox oil pressure
- Cable harness in different lengths
- Various instrument panels

### Power transmission

- PTO crankshaft front end, type stub shaft
- Hydraulic pump for steering and other duties

### Reverse gear

- ZF280

## Dimensions D7A TA/ZF280

Not for installation

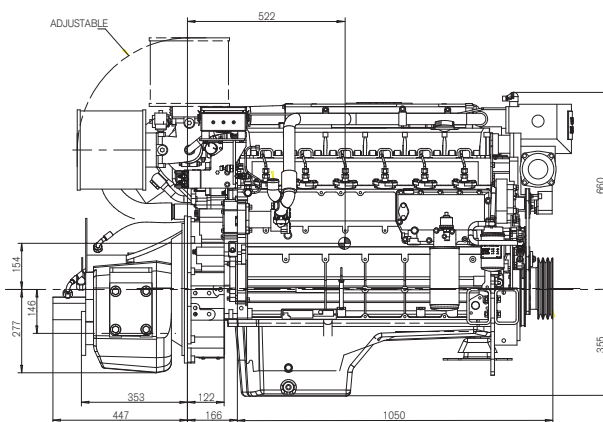
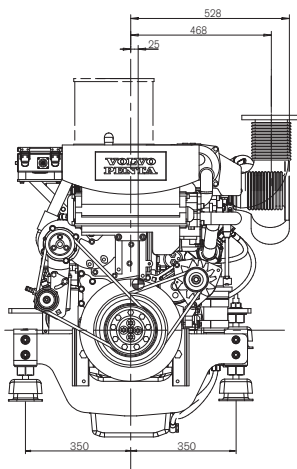

## More information

Contact your local Volvo Penta dealer for more information regarding Volvo Penta engines and optional equipment/accessories or visit [www.volvopenta.com](http://www.volvopenta.com)



IOS



Android

Download the Volvo Penta dealer locator App for your iPhone or Android



**CONTACTEZ NOUS POUR VOTRE  
PROJET DE (RE)MOTORISATION**

[www.dbmoteurs.fr](http://www.dbmoteurs.fr)  
[contactweb@dbmoteurs.fr](mailto:contactweb@dbmoteurs.fr)  
03 28 64 36 36



Not all models, standard equipment and accessories are available in all countries. All specifications are subject to change without notice. The engine illustrated may not be entirely identical to production standard engines.

**AB Volvo Penta**  
SE-405 08 Göteborg, Sweden  
[www.volvopenta.com](http://www.volvopenta.com)