

D5A TA

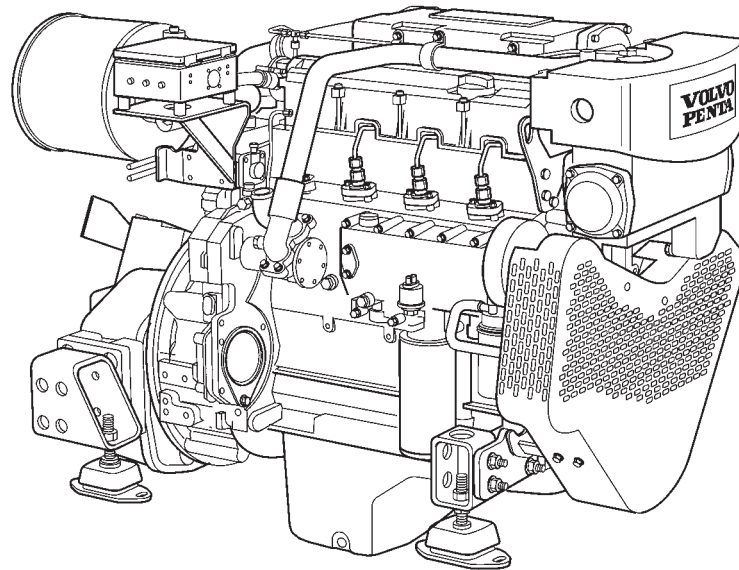

Technical Data

Engine designation	D5A TA		
No. of cylinders and configuration	in-line 4		
Method of operation	4-stroke, direct-injected, turbocharged diesel engine with aftercooler		
Bore/stroke, mm (in.)	108 (4.25)/130 (5.12)		
Displacement, l (in ³)	4.76 (290)		
Compression ratio	17.6:1		
Dry weight bobtail, kg (lb)	525 (1157)		
Dry weight with reverse gear ZF220, kg (lb)	570 (1257)		
	Rating 2 2300 rpm	Rating 1 2300 rpm	Rating 1 1900 rpm
Crankshaft power, kW (hp)	118 (160)	102 (139)	89 (121)
Max. torque, Nm (lbf.ft) @ 1500 rpm	579 (427)	490 (362)	490 (362)
Specific fuel consumption, g/kWh (lb/hph) @ 2300 rpm	210 (0.340)	214 (0.347)	
g/kWh (lb/hph) @ 1900 rpm			203 (0.329)
Recommended fuel to conform to	ASTM-D975 1-D & 2-D, EN 590 or JIS KK 2204		
Emission compliance	EU IWW, CCNR2		
Flywheel housing/SAE size	10"/11,5"/SAE2, 14"/SAE1		

Technical data according to ISO 3046 Fuel Stop Power and ISO 8665. Fuel with a lower calorific value of 42700 kJ/kg and density of 840 g/liter at 15 °C (60 °F). Merchant fuel may differ from this specification which will influence engine power output and fuel consumption.

Ratings R1 & R2, see explanation in Volvo Penta's Product Guide.

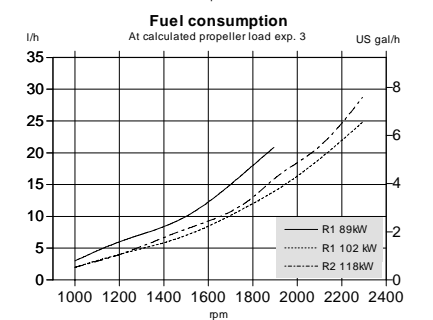
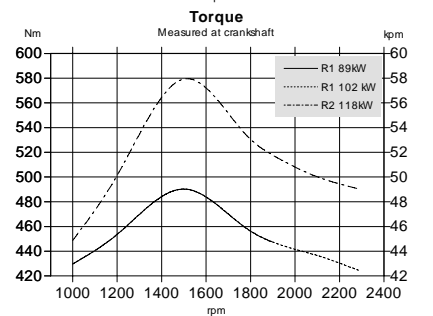
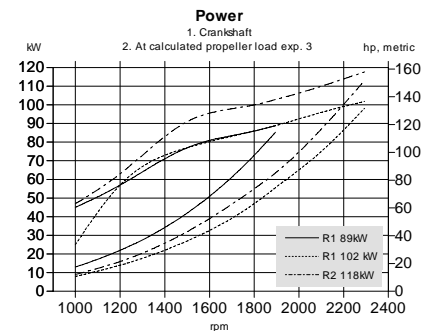

D5A TA

Technical description:

Engine and block

- Cylinder block, head and flywheel housing made of cast iron
- Belt guard
- Combined 10" and 11.5" flywheel with SAE 3 housing
- Nitrocarburized transmission gears
- Press-hardened crankshaft
- Forged aluminum pistons
- Cylinder liners of wet type

Lubrication system

- Oil filler in valve cover
- Oil sump made of cast iron
- Manual oil drain pump
- Rotary lubrication oil pump
- Freshwater-cooled oil cooler
- Full flow oil filters of spin-on type
- Closed crankcase ventilation system

Fuel system

- Fuel feed pump
- Fine fuel filter of spin-on type
- Unit pumps
- Six-hole injectors
- Mechanical governor with smoke limiter
- Fuel stopping solenoid 24V

Cooling system

- 2-circuit keel cooling system with expansion tank

- Gear-driven seawater pump
- Belt-driven freshwater pump
- Freshwater-cooled turbocharger and exhaust manifold

Electrical system

- 2-pole 24V electrical system, 24V/55A alternator, 24V 4kW starter
- Senders and switches:
 - Tachometer
 - Lubrication oil pressure
 - Cooling-water temperature
 - Cooling-water level
- Rubber-suspended electrical terminal box with semi-automatic fuses and plug-in connection

Optional equipment

Engine

- Flexible suspension for engine and reverse gear
- Combined 10"/11,5" flywheel with SAE 2 housing

Lubrication system

- Shallow oil sump
- Twin oil filters, for remote mounting

Fuel system

- Hand pump
- Jacketed fuel pipes
- Single or twin fuel/water separating pre filter

- Twin fuel filters, for remote mounting

Exhaust system

- Exhaust elbow, wet
- Exhaust elbow, dry, with integrated flexible compensator
- Silencer, dry

Cooling system

- Engine-mounted tubular heat exchanger with integrated expansion tank
- Seawater filter

Electrical system

- 1-pole 12V electrical system, 12V/95A alternator, 12V/3.1kW starter
- 24V/140A alternator
- Engine heater 230V/820W
- Senders:
 - Charge air pressure
 - Gearbox oil pressure
- Cable harness in different lengths
- Various instrument panels

Power transmission

- PTO crankshaft front end, type stub shaft
- Hydraulic pump for steering and other duties

Reverse gear

- ZF45

Dimensions D5A TA/ZF45

Not for installation

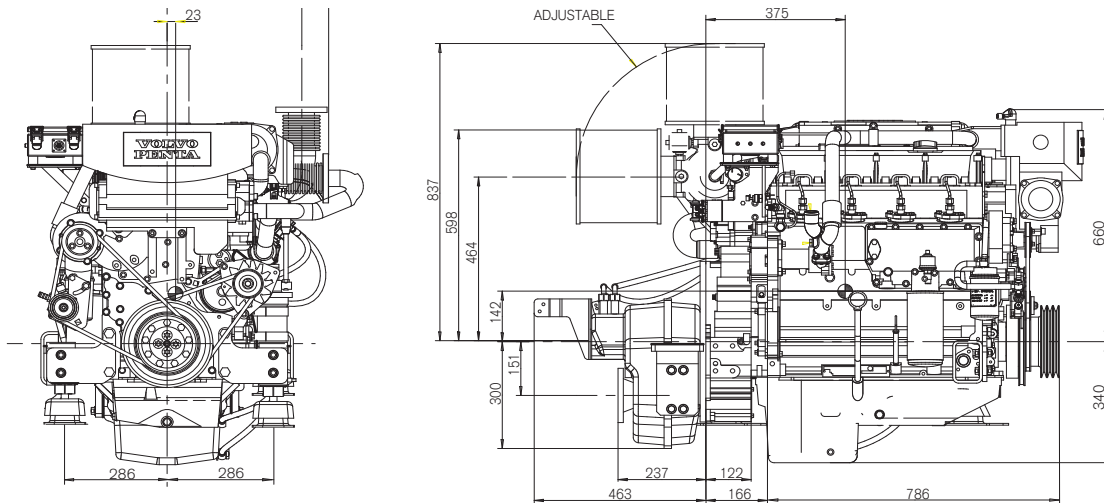

More information

Contact your local Volvo Penta dealer for more information regarding Volvo Penta engines and optional equipment/accessories or visit www.volvopenta.com



IOS



Android

Download the Volvo Penta dealer locator App for your iPhone or Android



**CONTACTEZ NOUS POUR VOTRE
PROJET DE (RE)MOTORISATION**

www.dbmoteurs.fr
contactweb@dbmoteurs.fr
03 28 64 36 36

AUTHORIZED
VOLVO PENTA CENTER

**VOLVO
PENTA**

AB Volvo Penta
SE-405 08 Göteborg, Sweden
www.volvopenta.com

Not all models, standard equipment and accessories are available in all countries. All specifications are subject to change without notice. The engine illustrated may not be entirely identical to production standard engines.