

TAD1360-1365VE is a powerful, reliable and economical Versatile Diesel Engine range built on the Volvo in-line six concept.

Low cost of ownership

World class fuel efficiency combined with a reliable engine aftertreatment system gives high uptime as well as low cost of ownership. No downtime for regeneration or decreased service intervals compared with current engine program.

Compact and simple installation

SCR technology selected by Volvo does not increase amount of cooling capacity needed. As optional equipment all material needed in order to install the engine can be ordered from Volvo Penta. Installation guidelines as well as drawings and CAD models are easy to access. The result is an engine and aftertreatment system that is easy to install with minor impact on existing machine layout.

Durability & low noise

Long experience with SCR systems in combination with base engine development reduces risk of downtime. Well-balanced to produce smooth and vibration-free operation with low noise

Power and torque

Maximum power and torque available at low rpm. As a result noise as well as fuel consumption is very low. Useful engine speed for the TAD1360-1365VE is due to power and torque layout very flexible.

Low exhaust emission

Efficient injection as well as robust engine design in combination with SCR technology contributes to excellent combustion and low fuel consumption. TAD1360-1365 VE complies with EU Stage IIIb / EPA Tier 4i emissions.

Easy service & maintenance

Easily accessible service and maintenance points contribute to the ease of service of the engine. As optional equipment possible to remote mount filters and service points.



- Low cost of ownership and operation due to SCR technology
- Proven and straight-forward design
- Compact and simple installation
- High power and torque available at low engine speed
- Complies with EU Stage IIIb / EPA Tier 4i
- Wide range of optional equipment, please see order specification

Technical description

Engine and block

- Cast iron cylinder block
- Wet, replaceable cylinder liners
- Replaceable valve guides and valve seats
- Overhead camshaft and four valves per cylinder

Lubrication system

- Full flow disposable spin-on oil filter, for extra high filtration
- Gear type lubricating oil pump, gear driven by the transmission
- Oil level sensor at startup

Fuel system

- Electronic high pressure unit injectors
- Fuel prefilter with water separator and water-in-fuel indicator / alarm
- Gear driven low-pressure fuel pump
- Fine fuel filter with manual feed pump and fuel pressure switch

Cooling system

- Available as Power pack or base engine.
- Belt driven coolant pump with high degree of efficiency

Turbocharger

- Electronically controlled Waste-gate

Electrical system

- Engine Management System 2 (EMS 2), an electronically controlled processing system which optimizes engine performance.
- The instruments and controls connect to the engine via the CAN SAE J1939 interface. Options for engine control equipment.

Engine aftertreatment system

- Emission levels compliance through SCR technology
- Several DEF tanks available as options
- Possibility to offer a wide range of installation material needed

TAD1360-1365VE

Technical Data

General

Engine designation	TAD1360-1365VE
No. of cylinders and configuration.....	in-line 6
Method of operation	4-stroke
Bore, mm (in.).....	131 (5.16)
Stroke, mm (in.).....	158 (6.22)
Displacement, l (in ³).....	12.78 (780)
Compression ratio.....	18.1:1
Wet weight, engine only, kg (lb).....	1237 (2921)
Oil system capacity incl filters, liter (US gal).....	36 (9.51)

Engine	kW	Hp	rpm	Nm
TAD1360VE	256	348	1900	1740
TAD1361VE	285	388	1900	1940
TAD1362VE	315	428	1900	2140
TAD1363VE	345	469	1900	2345
TAD1364VE	375	510	1900	2550
TAD1365VE	405	551	1900	2650

For details see Technical Data

Main components

The illustration shows the main components of the aftertreatment system and its piping connections.

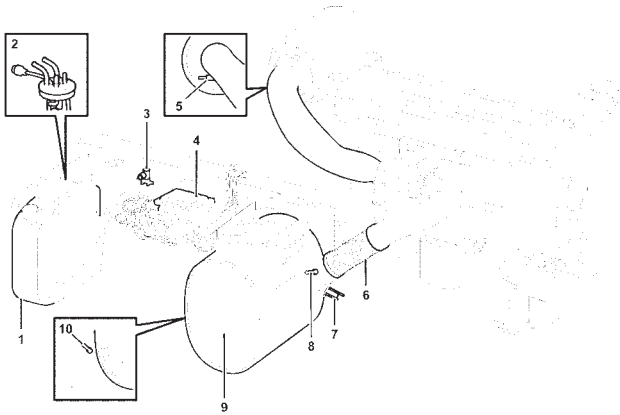

- 1 DEF tank
- 2 Heat, level, consumption
- 3 Warm-up valve
- 4 Supply Module (SM)
- 5 Humidity sensor
- 6 Flexible hose (stainless)
- 7 Dosing Module (DM)
- 8 Temperature sensor
- 9 SCR muffler
- 10 NOx sensor, exhaust pipe outlet.

Dimensions TAD1360-1365VE

Not for installation

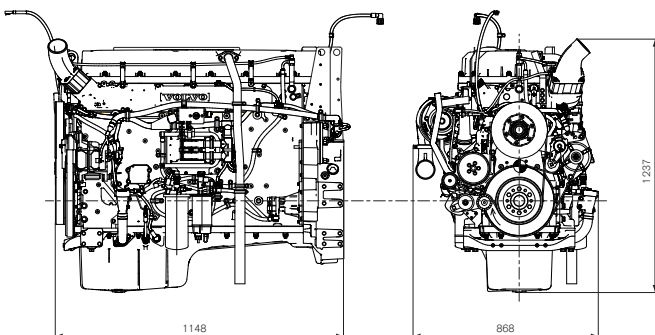

Note! Not all models, standard equipment and accessories are available in all countries. All specifications are subject to change without notice. The engine illustrated may not be entirely identical to production standard engines.

Power Standards

The engine performance corresponds to ISO 3046, BS 5514 and DIN 6271. The technical data applies to an engine without cooling fan and operating on a fuel with calorific value of 42.7 MJ/kg (18360 BTU/lb) and a density of 0.84 kg/litre (7.01 lb/US gal, 8.42 lb/imp gal), also where this involves a deviation from the standards.

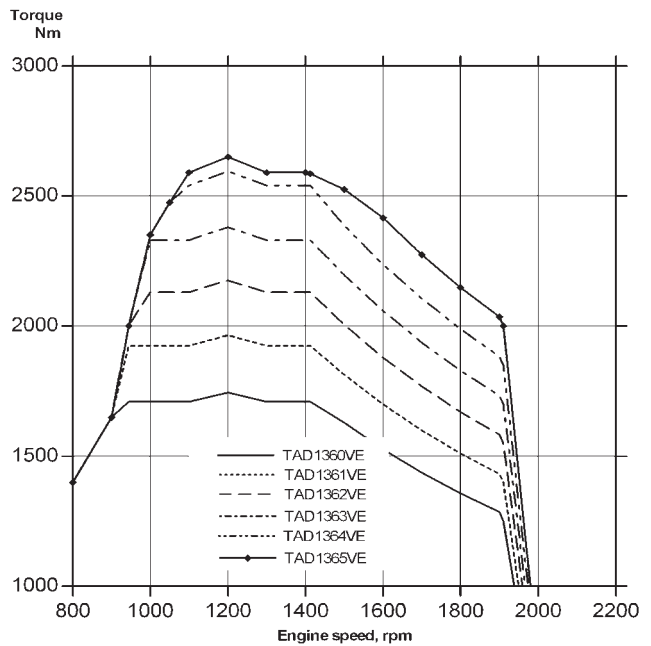
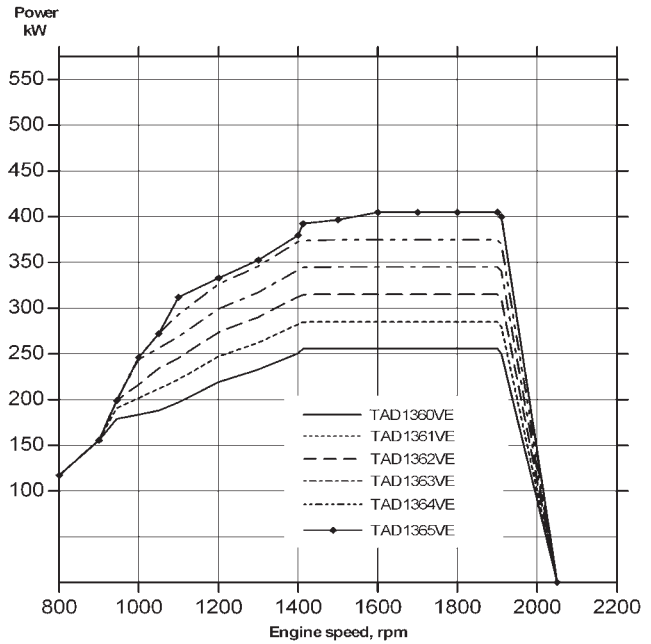

AB Volvo Penta
SE-405 08 Göteborg, Sweden
www.volvopenta.com