

## VOLVO PENTA MARINE GENSET

# D16 MG

16.1 liter, in-line 6 cylinder

490–631 kVA (392–505 kWe) at 1500 rpm 50Hz/400V, 588–695 kVA (470–556 kWe) at 1800 rpm 60Hz/440V



## DB MOTEURS

Volvo Penta Center  
[www.dbmoteurs.fr](http://www.dbmoteurs.fr)  
 03 28 64 36 36  
[contactweb@dbmoteurs.fr](mailto:contactweb@dbmoteurs.fr)

**CONTACTEZ-NOUS POUR VOTRE PROJET DE (RE)MOTORISATION  
 OU POUR TOUT BESOIN DE PIÈCES DÉTACHÉES VOLVO PENTA**

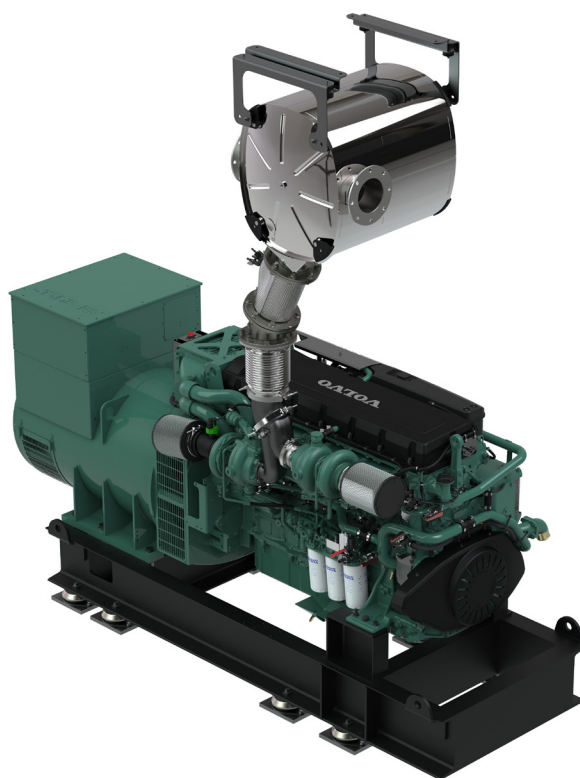

Engine designation	D16 MG / Stamford		
Configuration	in-line 6		
Method of operation	4-stroke, direct-injected, turbocharged diesel engine with charge air cooler		
Bore, mm	144		
Stroke, mm	165		
Displacement, l	16.1		
Compression ratio	16.8:1		
	<b>1500 rpm</b>	<b>1800 rpm</b>	<b>1800 rpm</b>
Crankshaft Power HE/KC, kW	532	532	585
Emission compliance	IMO Tier III	IMO Tier III, US EPA Tier 3	IMO Tier III
	-		-
Specific fuel consumption HE/KC, g/kWh			
	(50%) 195	201	199
	(75%) 194	199	197
	(100%) 195	199	200
Recommended fuel to conform to	ASTM-D975 1-D & 2-D, EN 590 or JIS KK 2204		

10% overload available acc. to class requirements. Fuel temperature 40°C (104°F). Technical data according to ISO 3046 Fuel Stop Power with a tolerance ±4%. Fuel with a lower calorific value of 42700 kJ/kg and density of 840 g/liter at 15°C (60°F). Merchant fuel may differ from this specification which will influence engine power output and fuel consumption. The engine is certified according to IMO Tier III for diesel electric propulsion.

# D16 MG

16.1 liter, in-line 6 cylinder

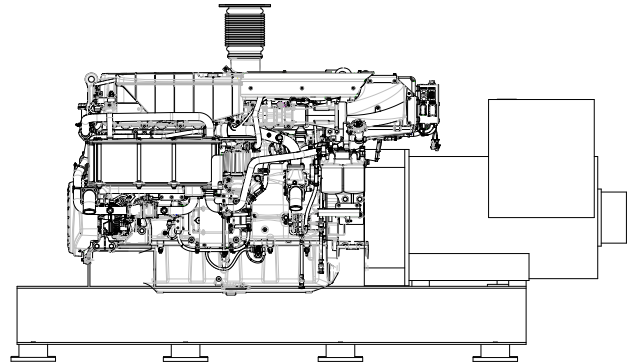
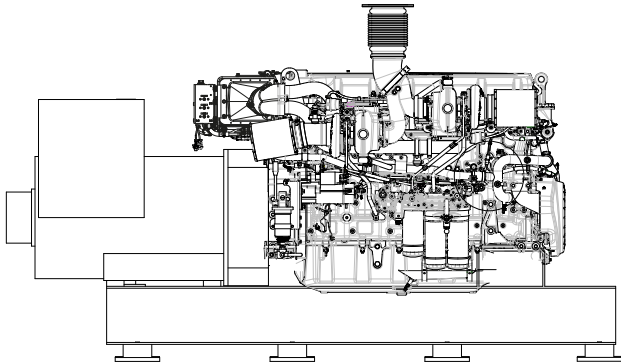

## Technical Data HE/KC Genset (Class F)

Power output at 1500 rpm 50Hz/400V, kVA (kWe)

D16 MG / S5L1ME41.....	490 (392)
D16 MG / S5L1MF41.....	525 (420)
D16 MG / S6L1MC41.....	.631 (505)

Power output at 1800 rpm 60Hz/440V, kVA (kWe)

D16 MG / S5L1ME41.....	588 (470)
D16 MG / S5L1MF41 (532kW) .....	.631 (505)
D16 MG / S5L1MF41 (585kW) .....	.644 (515)
D16 MG / S6L1MC41.....	694 (555)

10% overload available according to class requirements.  
 Fuel temperature 40°C (104°F). Technical data according to ISO 3046 Fuel Stop Power and ISO 8665. Fuel with a lower calorific value of 42700 kJ/kg and density of 840 g/liter at 15°C (60°F). Merchant fuel may differ from this specification which will influence engine power output and fuel consumption.

## Technical Data HE/KC Genset (Class H)

Power output at 1500 rpm 50Hz/400V, kVA (kWe)

D16 MG / S5L1ME41.....	530 (424)
D16 MG / S5L1MF41.....	585 (468)
D16 MG / S6L1MC41.....	.631 (505)

Power output at 1800 rpm 60Hz/440V, kVA (kWe)

D16 MG / S5L1ME41.....	625 (500)
D16 MG / S5L1MF41.....	694 (555)
D16 MG / S6L1MC41.....	694 (555)

10% overload available according to class requirements.  
 Fuel temperature 40°C (104°F). Technical data according to ISO 3046 Fuel Stop Power and ISO 8665. Fuel with a lower calorific value of 42700 kJ/kg and density of 840 g/liter at 15°C (60°F). Merchant fuel may differ from this specification which will influence engine power output and fuel consumption.

## Dimensions HE/KC L x W x H<sub>1</sub> (mm), not for installation

D16 MG / S5L1ME41.....	3122 x 1167 x 1840
D16 MG / S5L1MF41.....	3165 x 1167 x 1840
D16 MG / S6L1M-C4.....	3265 x 1167 x 1840

Weight HE, kg

D16 MG / S5L1ME41.....	3851
D16 MG / S5L1MF41.....	3991
D16 MG / S6L1MC41.....	4271

Weight KC, kg

D16 MG / S5L1ME41.....	3771
D16 MG / S5L1MF41.....	3911
D16 MG / S6L1MC41.....	4191

H<sub>1</sub> = Height including exhaust compensator

# D16 MG

16.1 liter, in-line 6 cylinder

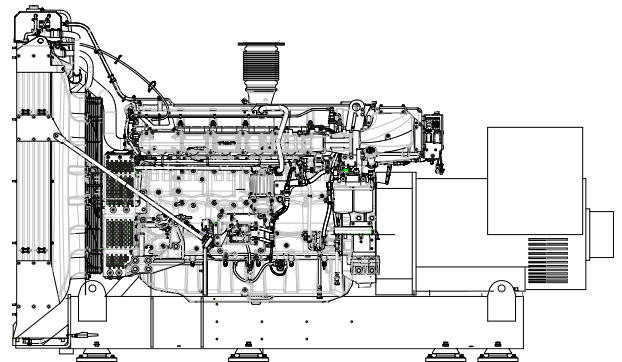
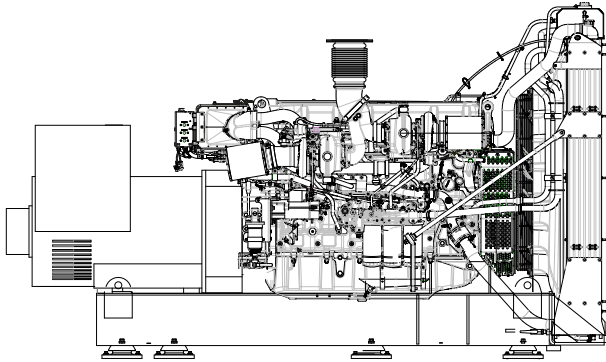

## Technical Data RC Genset (Class F)

Power output at 1500 rpm 50Hz/400V, kVA (kWe)	
D16 MG / S5L1ME41.....	490 (392)
D16 MG / S5L1MF41.....	525 (420)
D16 MG / S6L1MC41.....	.610 (488)
Power output at 1800 rpm 60Hz/440V, kVA (kWe)	
D16 MG / S5L1ME41.....	588 (470)
D16 MG / S5L1MF41.....	.644 (515)
D16 MG / S6L1MC41.....	.659 (527)

10% overload available according to class requirements.  
 Fuel temperature 40°C (104°F). Technical data according to ISO 3046 Fuel Stop Power and ISO 8665. Fuel with a lower calorific value of 42700 kJ/kg and density of 840 g/liter at 15°C (60°F). Merchant fuel may differ from this specification which will influence engine power output and fuel consumption.

## Dimensions L x W x H<sub>1</sub>/H<sub>2</sub> (mm), not for installation

D16 MG / S5L1ME41.....	.3448 x 1380 x 1840/2055
D16 MG / S5L1MF41.....	.3505 x 1380 x 1840/2055
D16 MG / S6L1MC41.....	.3606 x 1380 x 1840/2055
Weight, kg	
D16 MG / S5L1ME41.....	4025
D16 MG / S5L1MF41.....	4165
D16 MG / S6L1MC41.....	4445

H<sub>1</sub> = Height including exhaust compensator  
 H<sub>2</sub> = Total genset height including expansion tank

## Technical Data RC Genset (Class H)

Power output at 1500 rpm 50Hz/400V, kVA (kWe)	
D16 MG / S5L1ME41.....	530 (424)
D16 MG / S5L1MF41.....	585 (468)
D16 MG / S6L1MC41.....	.610 (488)
Power output at 1800 rpm 60Hz/440V, kVA (kWe)	
D16 MG / S5L1ME41.....	625 (500)
D16 MG / S5L1MF41.....	.661 (529)

10% overload available according to class requirements.  
 Fuel temperature 40°C (104°F). Technical data according to ISO 3046 Fuel Stop Power and ISO 8665. Fuel with a lower calorific value of 42700 kJ/kg and density of 840 g/liter at 15°C (60°F). Merchant fuel may differ from this specification which will influence engine power output and fuel consumption.

# D16 MG

16.1 liter, in-line 6 cylinder

## Technical description

### Complete Genset

- High system efficiency as a result of system optimization of the complete Genset
- All used components of highest quality from well reputed suppliers
- Reinforced set dimensioned for high output and low sound level
- Mono-block engine/generator rigidly mounted on a common bed frame
- Engine directly coupled to generator via a flexplate
- Flexible mountings including welding plates mounted under the frame

### Engine and block

- Cylinder block and cylinder head made of cast iron
- One piece cylinder head
- Ladder frame fitted to engine block
- Replaceable wet cylinder liners and valve seats/guides
- Drop forged crankshaft with induction hardened bearing surfaces and fillets with seven main bearings
- Four valve per cylinder layout with overhead camshaft
- Each cylinder features cross-flow inlet and exhaust ducts
- Gallery oil cooled forged steel pistons, three piston rings
- Rear-end transmission
- Closed crankcase ventilation
- Senders for oil pressure (after filter), oil temp, oil pressure, oil level, fuel pressure, freshwater pressure, exhaust temp, crankcase pressure, speed crank and cam, boost pressure/temp, seawater pressure (not KC or RC cool.), coolant level, coolant temp
- Exhaust temperature indication

### Lubrication system

- Freshwater-cooled oil cooler integrated in cylinder block
- Twin full flow oil filter of spin-on type and single by-pass filter

### Fuel system

- Electronic Unit Injectors
- Gear-driven fuel pump, driven by timing gear
- Electronically controlled injection timing
- 6-hole high pressure injector nozzles

- Twin engine-mounted spin-on fine fuel filters with change over valve

### Turbocharger

- Twin parallel turbocharger with water-cooled turbine housing and wastegate

### Heat Exchanger cooled system (HE)

- For seawater- and central-cooled Gensets
- Engine-mounted plate heat exchanger with expansion tank
- Electrically controlled two stage fresh water pump
- Rubber impeller raw water pump

### Radiator cooled system (RC)

- For aircooled Gensets
- V-belt-driven radiator fan
- Belt-driven centrifugal cooling water pump
- Water-cooled CAC (Charge Air Cooler)

### Keel cooled system (KC)

- 2-circuit cooling system
- Belt-driven centrifugal cooling water pump in HT circuit
- Engine mounted expansion tank in HT circuit
- Gear driven rubber impeller cooling water pump in CAC LT circuit

### Generator

- 4-pole, brushless, AC marine generator
- Temperature rise class F and class H
- Tropical insulation class H
- Stator winding as standard with short 2/3 pitch winding, ideal for non-linear load (thyristor load)
- Automatic Voltage Regulator (AVR) for accurate voltage regulation
- Permanent magnet mounted on generator for independent power supply to AVR
- Single bearing generator as standard
- Voltage available range up to 690V
- IP23 enclosure as standard
- Anti condensation heating

### Control System

Two options for control systems

1. MCC (Marine Commercial Control), an open system that is type-approved. Incl. separate safety shutdown system.
2. Open CAN Interface, engine delivered without control system. Different options with or without shut down senders and switches.

## Optional equipment

### Engine

- Twin fuel pre-filters/water separator with change over valve
- Flexible exhaust compensator
- Cooling water connection bellows
- Electrical and air starting systems available individually or in parallel.
- Raw water pressure indication (only in combination with raw water pump)
- Exhaust temperature indication
- Engine heater 2000W

### Generator

- Air inlet filters according to IP23
- Air inlet louvres/filters according to IP44
- Parallel equipment mounted in generator
- Thermistors (1 or 2 per phase) mounted in generator for temperature measurement of windings in generator
- PT100 elements (1 or 2 per phase) mounted in generator for temperature measurement of windings in generator
- Double bearing generator (on request)
- PT100 elements mounted in generator bearings for temperature measurement

### Exhaust aftertreatment system

- SCR (Selective Catalytic Reduction)
- Aqueous UREA solution 32% or 40%
- Complete system – developed, certified, and serviced by one company
- Fully integrated capabilities
- SCR unit reduces noise by up to 35 dBA
- Wide range of installation options available

### Miscellaneous

- 110A alternator with integrated charging sensor
- Basic toolkit
- Spare parts according to classification recommendations

Not all models, standard equipment and accessories are available in all countries. All specifications are subject to change without notice. The Genset illustrated may not be entirely identical to production standard Gensets.



## DB MOTEURS

Volvo Penta Center

[www.dbmoteurs.fr](http://www.dbmoteurs.fr)

03 28 64 36 36

[contactweb@dbmoteurs.fr](mailto:contactweb@dbmoteurs.fr)

CONTACTEZ-NOUS POUR VOTRE PROJET DE (RE)MOTORIZATION  
OU POUR TOUT BESOIN DE PIÈCES DÉTACHÉES VOLVO PENTA

Contact your local Volvo Penta dealer for more information regarding Volvo Penta engines and optional equipment/accessories or visit [www.volvopenta.com](http://www.volvopenta.com)



AB Volvo Penta

SE-405 08 Göteborg, Sweden  
[www.volvopenta.com](http://www.volvopenta.com)