

V8-430/DPS EVC

NEW!

Technical Data

Engine designation	V8-430-CE
Crankshaft power, kW (hp)	317 (431)
Propeller shaft power, kW (hp)	292 (397)
Engine speed, rpm	6000
Displacement, l (in ³)	6.0 (364)
Number of cylinders	V8
Bore/stroke, mm (in.)	101.6/91.9 (4.00/3.62)
Compression ratio	9.67:1
Fuel system	Multi-port Injection
Volvo Penta Duoprop drive	DPS
Ratio	1.95:1, 2.14:1, 2.32:1*
Dry weight with DP, incl. prop. & PS, kg (lb)	506 (1115)
Rating	5**

The engine complies with **US EPA, CARB, EU RCD**

Power and fuel consumption measurements according to ISO 8665. Fuel octane of 90 RON (87 AKI) with 0% ethanol and density of 742g/liter, air temperature at 25°C (77°F), humidity of 30% and barometric pressure at 100 kPa (14.5 PSI). Operation at different conditions will influence engine power output and fuel consumption.

* High altitude 1500m (5000 feet)

** RATING 5, for pleasure craft applications

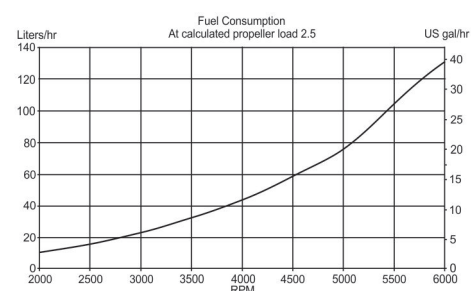
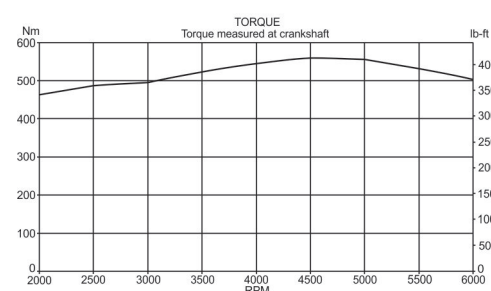
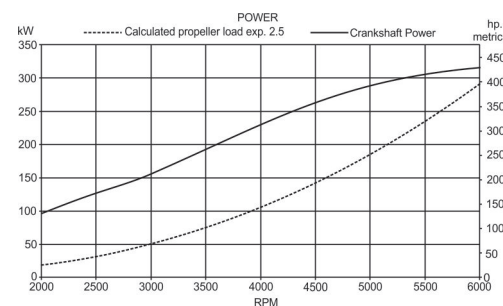
**VOLVO
PENTA**

Plus d'informations sur : www.dbmoteurs.fr

V8-430/DPS EVC

Technical description:

Engine block and head

- Deep skirt cylinder block with six bolt, powdered metal main caps for extra strength
- Hydraulic cam phaser for variable camshaft timing optimizes low end torque and high-end horse power
- High flow aluminum cylinder heads featuring fully CNC machined intake and exhaust ports resulting in improved airflow
- High lift intake and exhaust cam profiles optimized for maximizing high speed efficiency while maintaining idle quality
- Hollow stem, heavy duty intake valve stems reduce dynamic loading of valve train
- Inconel exhaust valves for prolonged life

Lubrication system

- Pressure lubrication system with heavy duty engine oil cooler and remote oil filter
- Paper oil filter element reduces environmental impact of engine service

Fuel system

- Multi Port Fuel Injection system
- Vapor separating fuel pump system with two electric pumps, pressure regulator, and water separating fuel filter

Intake and exhaust system

- Low weight aluminum exhaust system
- Exhaust passages optimized for torque and power

- Manifolds cooled by engine coolant as part of the standard freshwater cooling system
- Collector (elbow) design maximizes use of the catalyst for reduced back pressure
- 3 inch riser option is a direct replacement for the standard height elbow

Cooling system

- Full freshwater (closed) cooling system for engine, exhaust manifolds, engine oil cooler
- Advanced Volvo VCS (yellow) coolant for superior corrosion and thermal protection

Electronic engine control

- Electronic Control Module (ECM) ensures constant, optimum performance, greater fuel efficiency and reduced emissions
- 4G ECM supports full diagnostics through connection on engine harness
- Closed loop system with pre- and post catalyst oxygen sensors helps control fuel delivery and reduce emissions

Electrical system

- 12V corrosion-protected electrical system
- 75A marine alternator with internal transistorized voltage regulator
- Re-settable circuit breaker for trim system
- Fuse protection of the fuel pumps and the fuel injection system

Electronic Vessel Control

- Joystick control available as an option for twin installations

- Electronic shift and throttle
- Complete instrumentation including e-key switch and interlocked alarm
- Digital Power Trim instrument with analog or digital reading
- EVC monitoring panels for single or twin installations

Drive

- Cone clutch for smoother shifting
- Pattern-matched spiral bevel gears
- Exhaust through propeller hub, cavitation plate
- Break-away coupling between vertical shafts
- Standard tilt specification 52° (42° and 32° available as option on engine order)
- The drive can be turned 28° in each direction
- Built-in kick-up function to reduce damage, in the event the drive strikes an underwater object
- Easy access drive and transom shield anodes
- Optional electronic steering – prerequisite for Sterndrive Joystick, twin installation only

Power trim

- High capacity trim pump integrated with transom shield to ease installation and save space in engine compartment

Dimensions V8-430/DPS

Not for installation

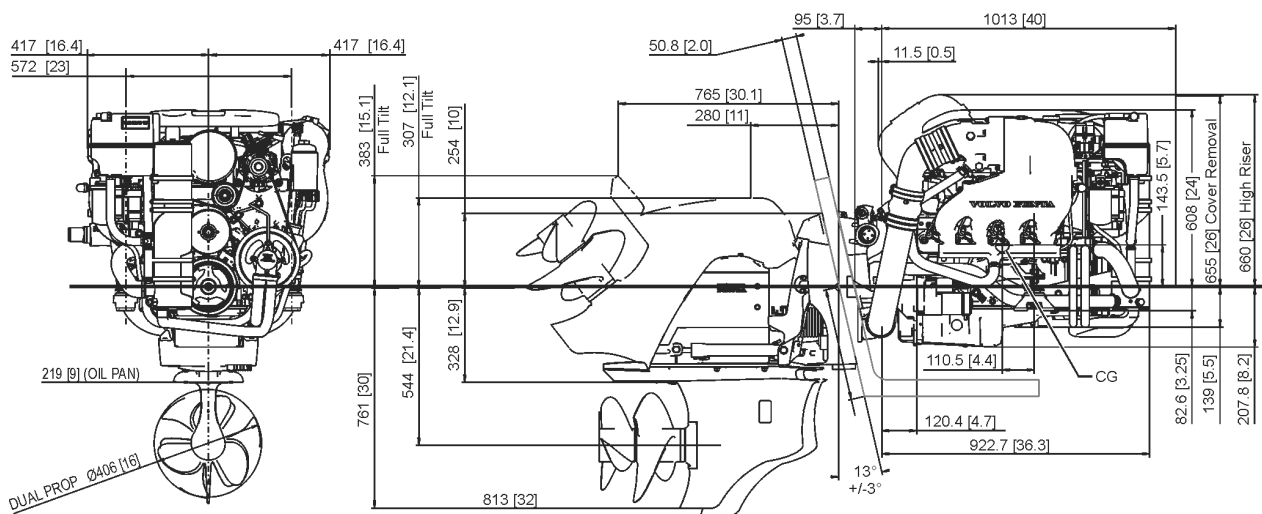

More information

Contact your nearest Volvo Penta dealer for more information about Volvo Penta engines and optional equipment/accessories or go to www.volvopenta.com



IOS



Android

Download the Volvo Penta dealer locator App for your iPhone or Android

VOLVO PENTA

AB Volvo Penta

SE-405 08 Göteborg, Sweden
www.volvopenta.com

Not all models, standard equipment and accessories are available in all countries. All specifications are subject to change without notice. The engine illustrated may not be entirely identical to production standard engines.

Plus d'informations sur : www.dbmoteurs.fr